

1,2,3 Hello Chaplin!!

(Charlie Chaplin paper bricks)

Created by Shoko Aoyagi
Diagrams by Shoko Aoyagi

©Shoko Aoyagi January 2008

You need 2 sheets of origami paper for this model.

Trousers

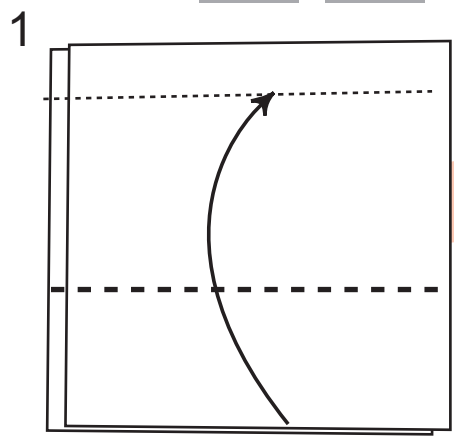

Fold 2 sheets of paper together to make the same crease lines.

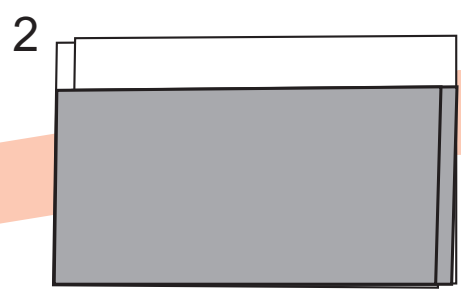

Take them apart.

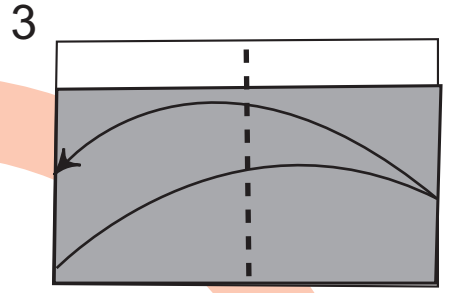

Fold in half. Crease well and unfold

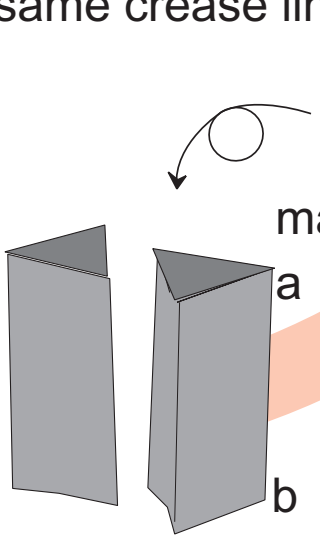

make x 2

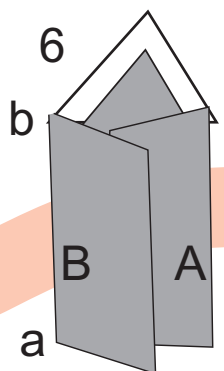

Insert flap A into flap B to make the paper 3-D.

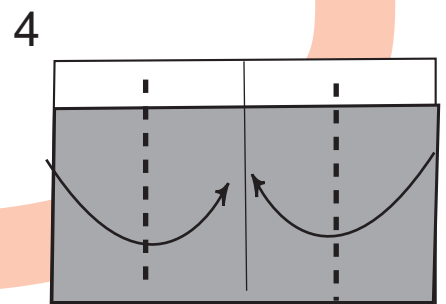
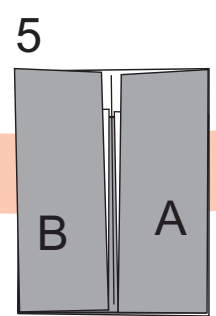

You now have 2 legs. or a pair of trousers.

(Charlie Chaplin paper bricks)

Created by Shoko Aoyagi
Diagrams by Shoko Aoyagi

©Shoko Aoyagi January 2008

Sleeves



1

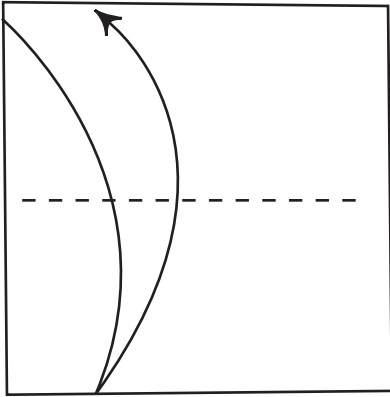

2

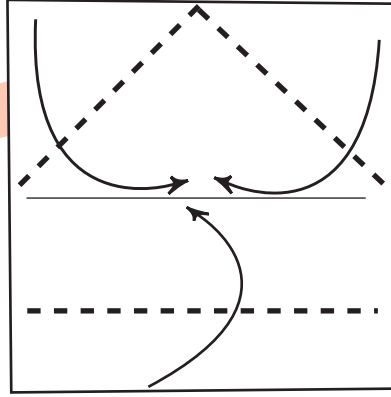

3

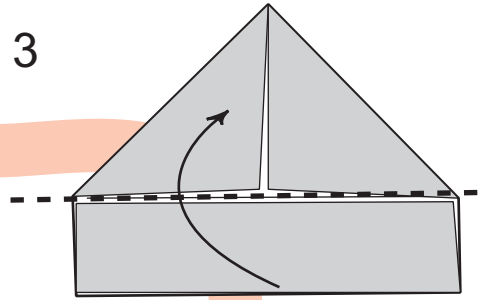

4

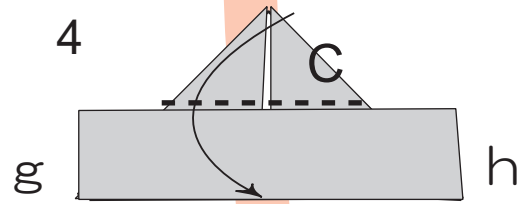

Insert the triangular flap C into the pocket D.
Make the jacket 3-D.

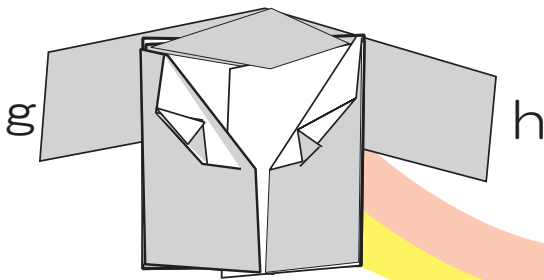

On the lapel of the jacket
the first fold is a valley and
second fold is a mountain.

pocket D

5

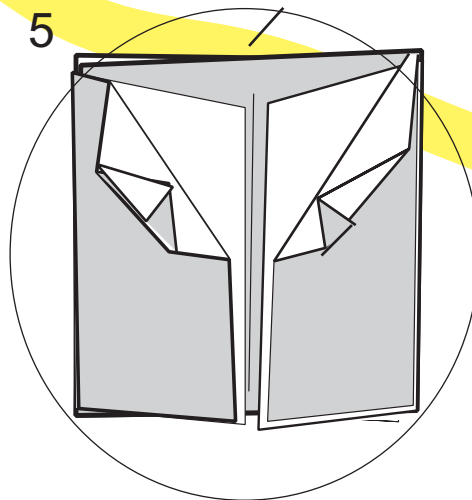

4

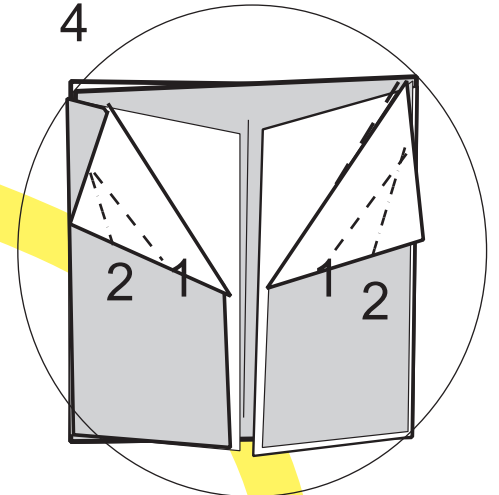

Jacket



1

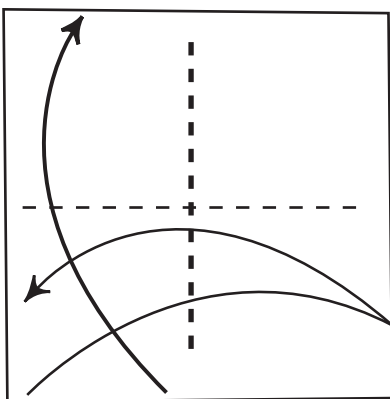

2

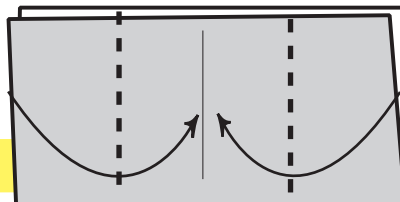

3

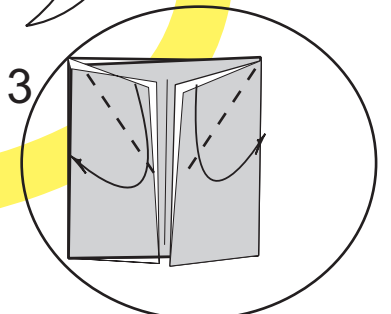

1, 2, 3 Hello Chaplin!!

(Charlie Chaplin paper bricks)

Created by Shoko Aoyagi
Diagrams by Shoko Aoyagi

©Shoko Aoyagi January 2008

Head



Moustache
(1/4)

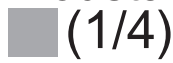

1

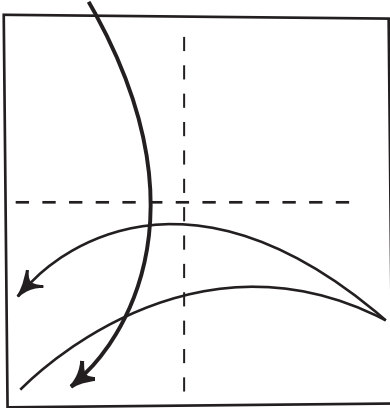

2

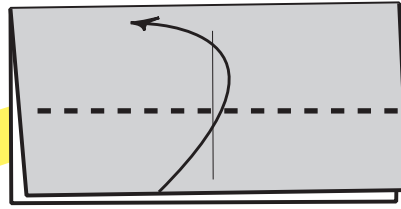

3

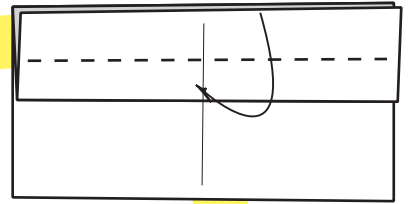

4

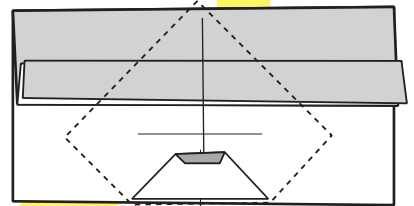

5

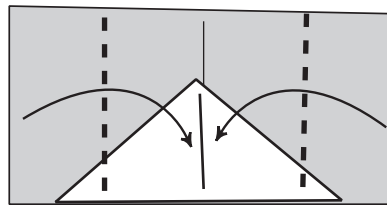

Insert the head into the moustache.

8

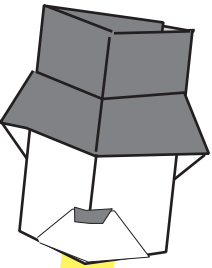

6

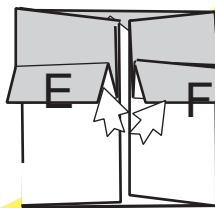

Open

Pull E and F outward and squash fold as shown.

7

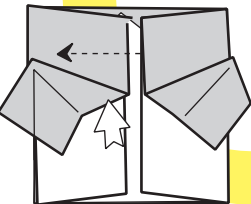

Moustache

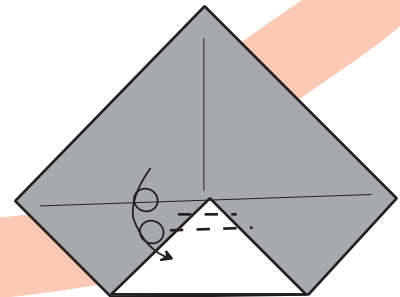
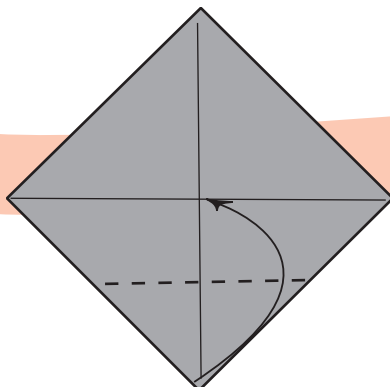
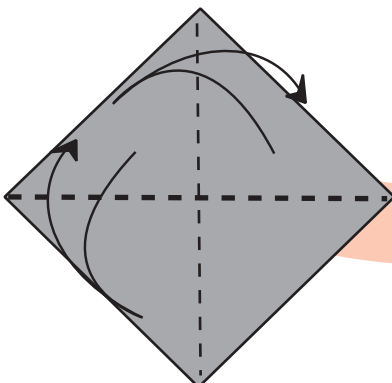

Fold twice.

1,2,3 Hello Chaplin!!

4/4

(Charlie Chaplin paper bricks)

Created by Shoko Aoyagi
Diagrams by Shoko Aoyagi

©Shoko Aoyagi January 2008

1

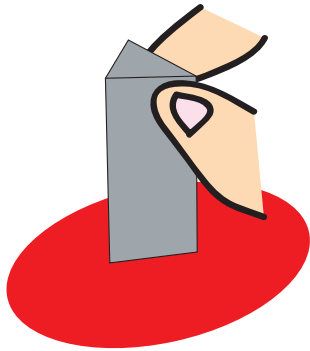

2

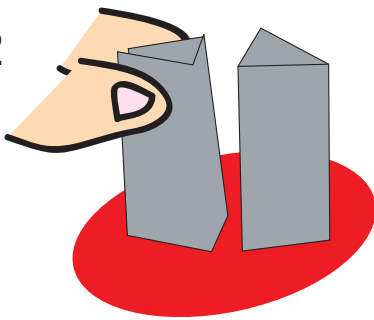

3

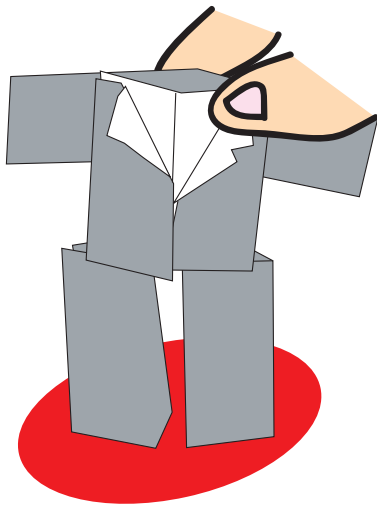

4

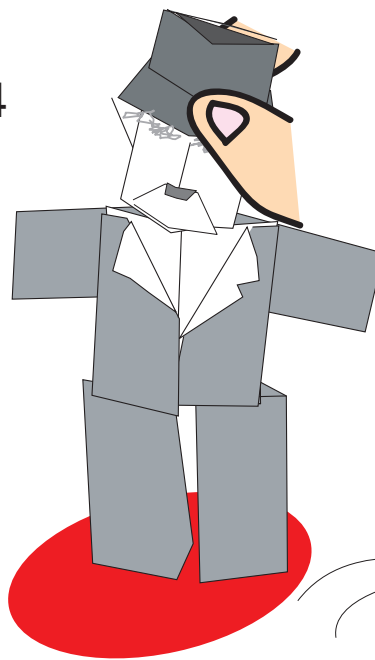

Hello Chaplin!!



Hint:
If you make shorter trousers, it could be
Henri de Toulouse-Lautrec. Enjoy!