

Bear Card

© Shoko Aoyagi July 2004

You need a sheet of A size paper. Photo copy paper will do.

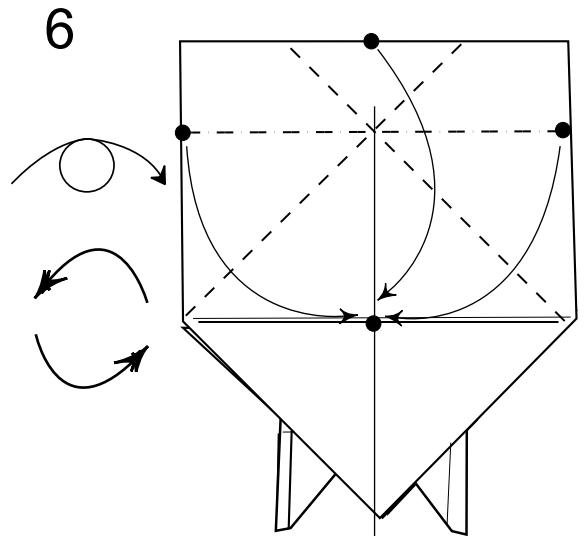
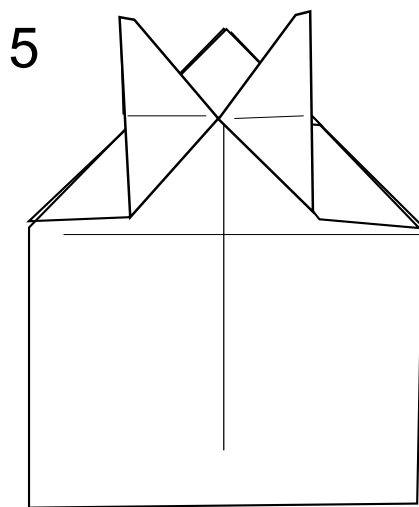
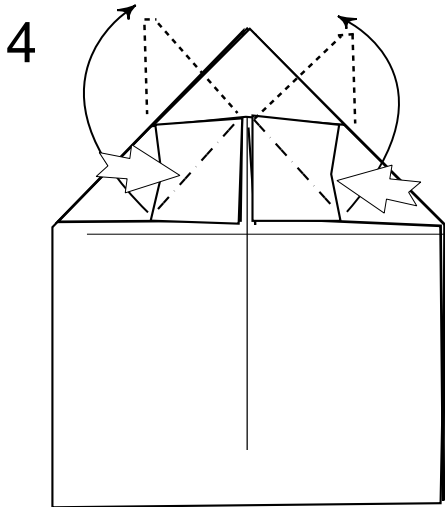
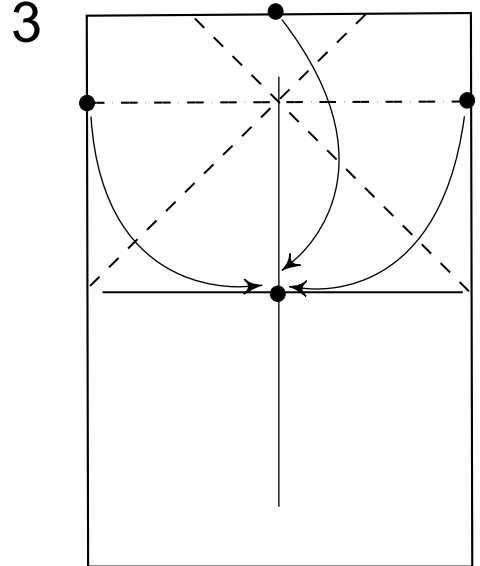
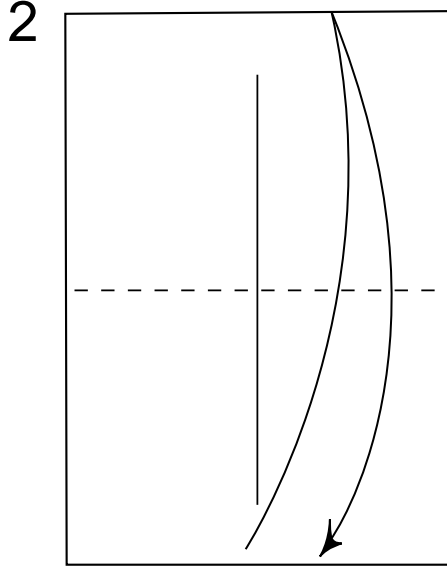
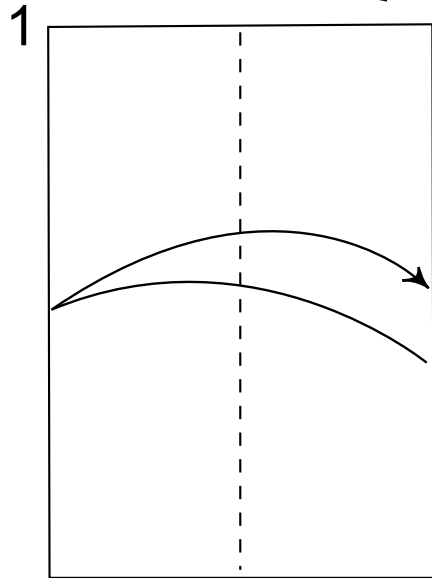
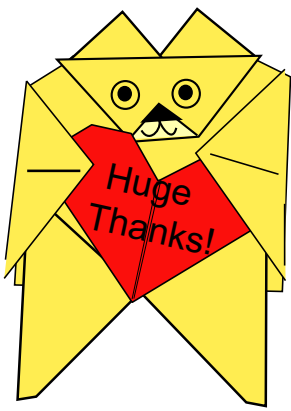

Repeat step 3 to 5.

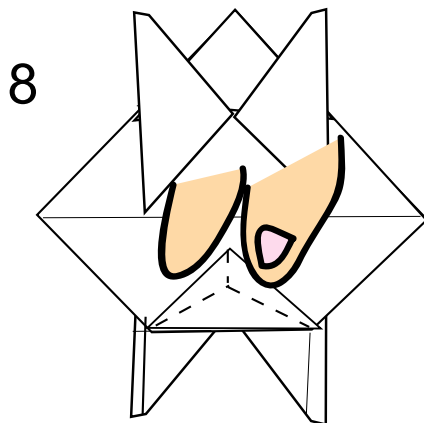
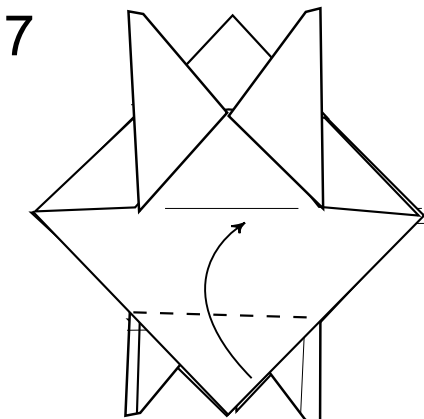

Pinch fold.

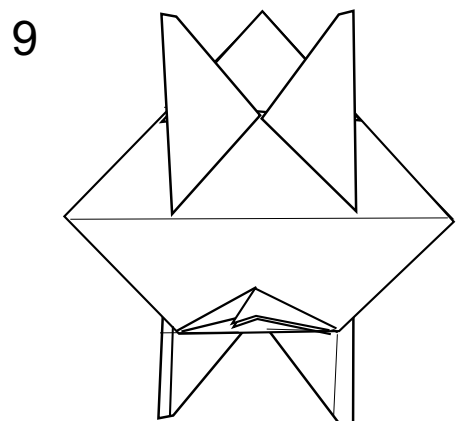

This is the result.

Bear Card

© Shoko Aoyagi July 2004



10

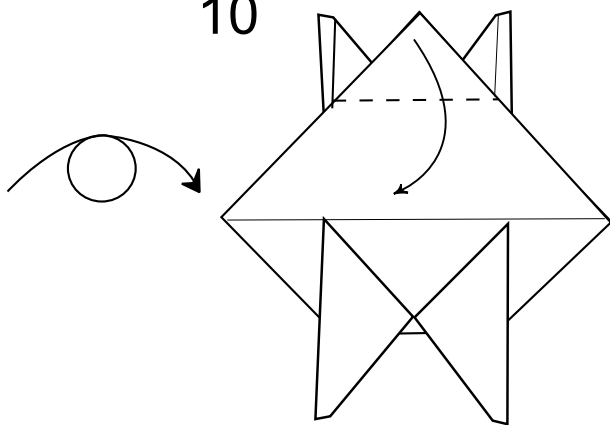

11

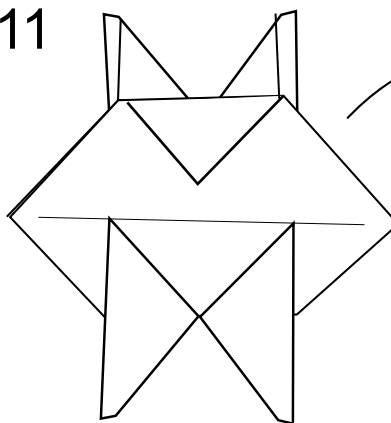

12

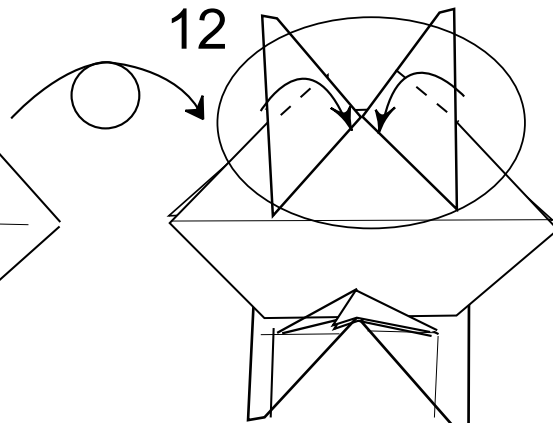

13

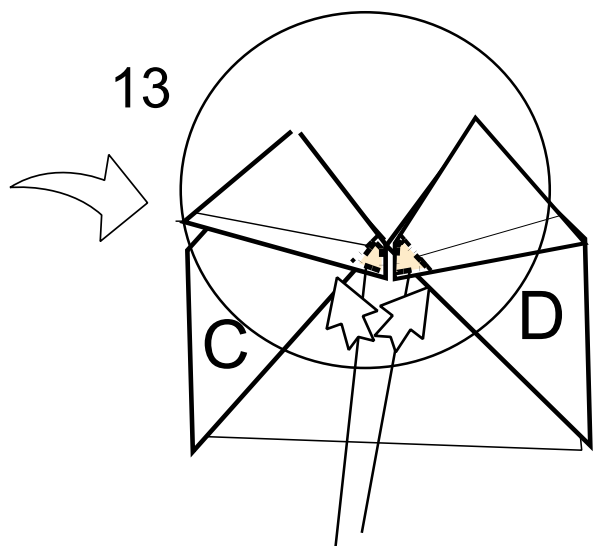

14

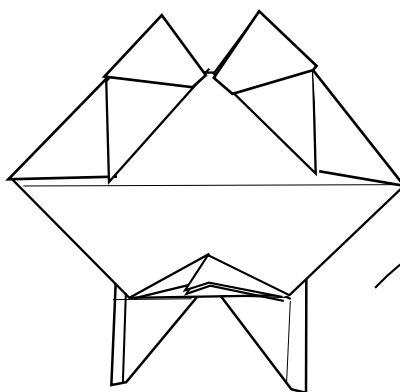

15

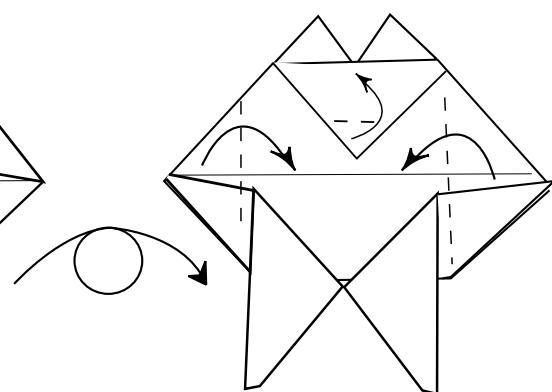

Tuck the 2 corners under the flaps 'C' and 'D'.

This is the result.

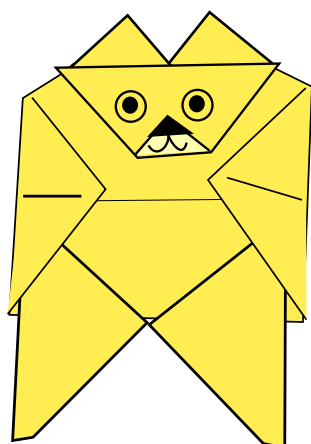

Front

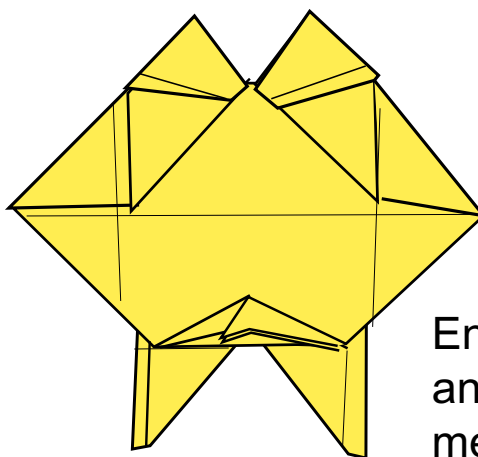

Back



Enjoy drawing the face and writing some messages . Here is the bear card.